

GUIDE TO LOW VOLTAGE CIRCUIT-BREAKER STANDARDS

In accordance with BS EN 60898 series
and BS EN 60947-2

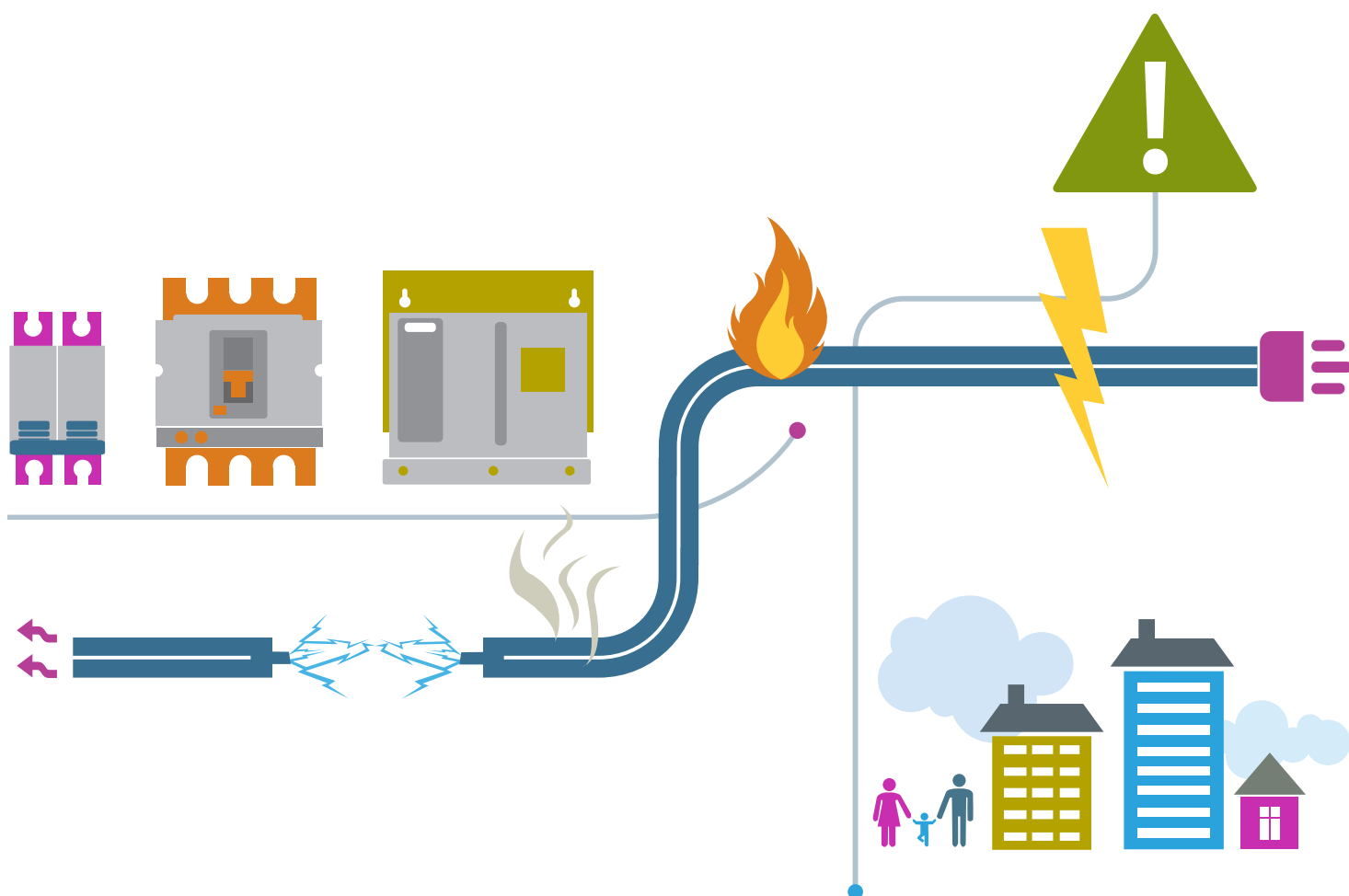

ABOUT BEAMA

BEAMA is the long established and respected trade association for the electrotechnical sector. The association has a strong track record in the development and implementation of standards to promote safety and product performance for the benefit of manufacturers and their customers.

This guide is intended as a practical guide for designers, specifiers and installers to enable them to specify low voltage circuit-breakers in accordance with the BS EN 60898 series and BS EN 60947-2.

This guide should be read in conjunction with these standards as it provides additional explanation on each section.

This Guide has been produced by BEAMA's Building Electrical Systems Sector operating under the guidance and authority of BEAMA, supported by specialist central services for guidance on UK Internal Market, European Single Market, Quality Assurance, Legal and Health & Safety matters. BEAMA's Building Electrical Systems Sector comprises of major UK manufacturing companies.

Details of other BEAMA Guides can be found on the BEAMA website www.beama.org.uk

ACKNOWLEDGEMENTS

BEAMA would like to thank BSI, CENELEC and IEC for allowing references to their standards.

DISCLAIMER

This publication is subject to the copyright of BEAMA Ltd. While the information herein has been compiled in good faith, no warranty is given or should be implied for its use and BEAMA hereby disclaims any liability that may arise from its use to the fullest extent permitted under applicable law.

© BEAMA Ltd 2022

Copyright and all other intellectual property rights in this document are the property of BEAMA Ltd. Any party wishing to copy, reproduce or transmit this document or the information contained within it in any form, whether paper, electronic or otherwise should contact BEAMA Ltd to seek permission to do so.

COMPANIES INVOLVED IN THE PREPARATION OF THIS GUIDE



ABB Ltd

Tower Court; Courtaulds Way
Foleshill Enterprise Park
Coventry, West Midlands CV6 5NX
Tel: +44 (0) 2476 368 500
<https://new.abb.com/uk>



Contactum Limited

Victoria House, 2 Blackmoor Lane,
Croxley Green Business Park,
Watford, WD18 8GA

Tel: 0208 208 7400
enquiries@contactum.co.uk



Powering Business Worldwide

Eaton Electric Limited

252 Bath Road, Slough,
Berkshire SL1 4DX

Tel: +44 (0) 8700 545 333
Email: ukcommorders@eaton.com
www.eaton.com/uk



GreenBrook Electrical

62 West Road, Harlow,
Essex CM20 2BG

Tel + 44 (0) 1279 772772
www.greenbrook.co.uk



Hager Ltd

Hortonwood 50, Telford,
Shropshire TF1 7FT

Tel: +44 (0)1952 675 689
Email: Technical@hager.co.uk
www.hager.co.uk



Legrand Electric Ltd

Great King Street North,
Birmingham B19 2LF

Tel: +44 (0) 345 605 4333
Email: legrand.sales@legrand.co.uk
www.legrand.co.uk



Lewden

Unit 4, Bradbury Drive
Springwood Industrial Estate
Braintree, Essex, CM7 2SD
Tel: +44 01376 336200
sales@lewden.co.uk



Luceco plc

Luceco Distribution Centre,
Stafford Park 1, Telford,
Shropshire, TF3 3BD

Tel: +44 (0)1952 238 100
uk_sales@luceco.com



Schneider Electric Ltd

Stafford Park 5, Telford, Shropshire TF3 3BL

Tel: +44 (0) 1952 290029

Fax: +44 (0) 1952 292238

www.schneider-electric.co.uk



Electrium Sales Ltd (a Siemens Company)

Walkmill Lane, Bridgetown
Cannock, WS11 0XE

Tel: +44 (0) 1543 455000

Email: info@electrium.co.uk

www.electrium.co.uk



A **theben** Group Company

Timeguard Ltd

Victory Park, 400 Edgware Road
London NW2 6ND

Tel: +44 (0) 20 8450 0515

Fax: +44 (0) 20 8450 0635

Email: helpline@timeguard.com

www.timeguard.com



RESEARCH & DEVELOPMENT

Western Automation R&D

2 Atreus Place, Poolboy, Ballinalsoe,
Co. Galway, Ireland H53 TD 78

Tel: +353 (0) 90 9643359

Fax: +353 (0) 90 9643094

Email: info@westernautomation.com

www.westernautomation.com

CONTENTS

Abbreviations, Definitions and Standards	5
1. Standards	6
1.1. Low voltage Circuit-Breaker standards	6
2. Types of Circuit-Breaker	7
2.1. Miniature Circuit-Breakers (MCBs)	8
2.2. Moulded Case Circuit-Breakers (MCCBs)	8
2.3. Air Circuit-Breakers (ACBs)	8
3. Low voltage Circuit-Breakers for use in household and similar installations	9
3.1. History of the development of 60898	9
3.2. BS EN 60898 Characteristics	9
3.3. BS EN 60898 Time/Current Characteristics	10
3.4. BS EN 60898 – Rated Values	11
3.5. Installation Factors	15
4. Low Voltage Circuit-Breakers for use in for use in industrial, large commercial and similar installations	19
4.1. History of the development of BS EN 60947-2	19
4.2. BS EN 60947-2 Characteristics	20
4.3. BS EN 60947-2 Rated Values	22
4.4. Installation Factors	25
4.5. Determination of maximum earth Loop impedance (Z_s)	25
4.6. Harmonic currents	27
5. Technical and Application Data –Low Voltage Circuit-breakers to BS EN 60898 series and BS EN 60947-2	29
5.1. Circuit-breaker substitution in assemblies	29
5.2. Functional switching with circuit-breakers	29
5.3. Coordination of Low voltage Switchgear and Controlgear assemblies with conductors operating at a temperature exceeding 70°C e.g. XLPE	29
5.4. Overcurrent coordination of devices from different manufacturers	30

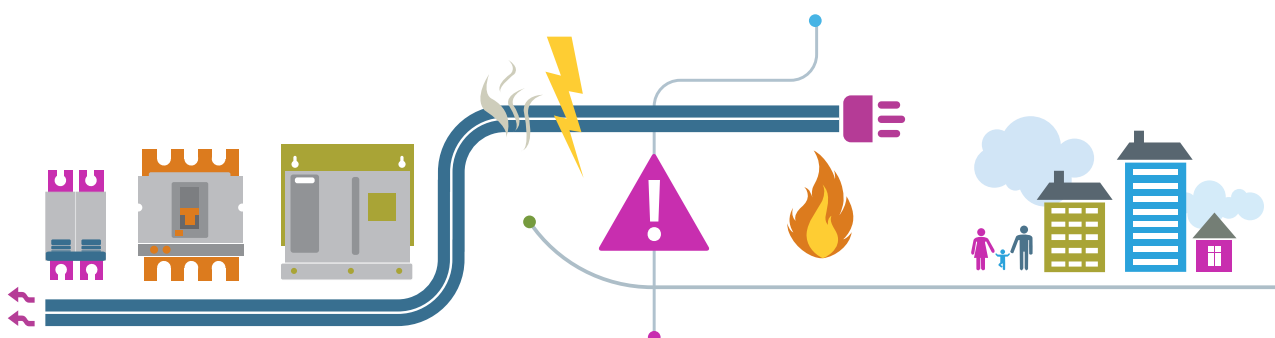

ABBREVIATIONS, DEFINITIONS AND STANDARDS

BSI	The United Kingdom National Standards Body appointed by the UK Government. BSI represents UK interests at the International Organization for Standardization (ISO), the International Electrotechnical Commission (IEC) and the European Standards Organizations (CEN, CENELEC and ETSI) and is the sole body with the authority to publish British Standards.
CENELEC	Designated as a European Standards Organization by the European Commission, CENELEC is the European Committee for Electrotechnical Standardization responsible for standardization in the electrotechnical engineering field.
IEC	International Electrotechnical Commission – body responsible for International Electrotechnical Standardization bringing together more than 170 countries and providing a global, neutral and independent standardization platform to 20 000 experts globally.
LVD	The Low Voltage Directive – European Union (EU) directive giving the principle elements of the safety objectives for low voltage equipment. (2014/35/EU).
EESR	UK implementation of the LVD: Electrical Equipment (Safety) Regulations 2016 (as amended).
CE	The letters 'CE' appear on many products traded on the extended Single Market in the European Economic Area (EEA). They signify that products sold in the EEA have been assessed to meet high safety, health, and environmental protection requirements.
UKCA	The UKCA (UK Conformity Assessed) marking is a new UK product marking that is used for goods being placed on the market in Great Britain (England, Wales and Scotland). It covers most goods which previously required the CE marking.
ACB	Air Circuit-Breaker.
MCB	Miniature Circuit-Breaker.
MCCB	Moulded Case Circuit-Breaker.
RMS	Effective value of an alternating current (heating effect). Mathematically derived from the square root of the mean squares of the instantaneous values.
RCBO	Residual Current circuit-Breaker incorporating Overcurrent protection.
SCPD	Short-Circuit Protective Device intended to protect a circuit or parts of a circuit against short-circuit currents by interrupting them.
BS 7671	Requirements for Electrical Installations. IET Wiring Regulations. Current edition BS 7671:2018/A2:2022.
BS EN 60898-1	Electrical accessories. Circuit-breakers for overcurrent protection for household and similar installations. Circuit-breakers for a.c. operation. Current edition BS EN 60898-1: 2019.
BS EN 60898-2	Electrical accessories. Circuit-breakers for overcurrent protection for household and similar installations. Circuit-breakers for a.c and d.c. operation. Current edition BS EN 60898-2: 2016.
BS IEC 60898-3	Electrical accessories. Circuit-breakers for overcurrent protection for household and similar installations. Circuit-breakers for DC operation. Current edition BS IEC 60898-3: 2019.
BS EN 60947-2	Low-voltage switchgear and controlgear. Circuit-breakers. Current edition BS EN 60947-2:2017+A1:2020.

1. STANDARDS

1.1 Low Voltage Circuit-Breaker Standards

1.1.1. Harmonisation

In an ideal world, the compatibility of manufactured goods across a wide geographical area can remove barriers to trade and can result in an efficiency of scale due to increased manufacturing volumes which in turn can reduce costs. In the electrical industry, appropriate standardisation could mean common supply networks and products; and in low voltage circuit-breaker applications can result in:

- ability to use compatible equipment;
- no need to adapt or modify such products;
- fewer limitations on the source of supply.

To this end considerable progress has already been made by the national standards committees of over 80 nations who are co-operating to formulate world standards which provide a consensus of international opinion on electrical supply and harmonisation.

1.1.2. World Standards

Participating countries comprise the International Electrotechnical Commission (IEC).

Most of these participating countries already have their own national standards which may differ from elements of the IEC Standards. However, when a need for harmonisation is identified, documents produced by the IEC may, where appropriate, form the basis for future national standards.

1.1.3. European Standards

Within Europe, harmonisation of electrical products is the responsibility of CENELEC (Comite Européenne de Normalisation Electrotechnique) which produces appropriate European standards generally based on the work of the IEC, once a need has been identified and agreed.

CENELEC is made up of over 30 national standards committees of the European Union and EFTA (European Free Trade Association). Whilst a European Standard can be a direct replica of an IEC standard, discussions within CENELEC may result in the formulation of a standard which includes commonly agreed modifications.

Two types of publication exist: the European Norm (prefixed EN-) and the Harmonised Document (prefixed HD-) where EN- qualifies the adoption of the standard by all member countries without deviation; and HD- a document that does not have to be adopted as a national standard but no conflicting national standards must exist.

The numbering of an EN- or HD- indicates the presence or otherwise of an IEC Standard. The 6xxxx series indicates that a EN or HD is based on a published IEC document whilst 5xxxx series indicates that the EN or HD originated in Europe and there is no published IEC equivalent document.

Since 2020, an EN standard that is derived from an IEC standard carries the designation EN IEC 6XXXX.

1.1.4 United Kingdom Standards

Adoption of the European Standard (EN) within the EU is mandatory. The UK has left the EU. However, BSI, remains a member of CENELEC and as such is obliged to adopt ENs. In the UK such standards are further endorsed with the additional 'BS' prefix, for example: BS EN 60898, the British Standard for circuit-breakers for overcurrent protection for household and similar installations.

Following UK's exit from the EU, the UK government has implemented a system that confers presumption of conformity with the safety objectives of the Electrical Equipment (Safety) Regulations via what are called 'Designated standards'. At the time of publication of this Guide, the list of designated standards for circuit-breakers matched the EU OJ list of harmonized standards for circuit-breakers. Circuit-breakers conforming with the safety objectives of the Electrical Equipment (Safety) Regulations are required to be UKCA marked.

NOTE: At the time of publication of this Guide, EU directives continue to apply in Northern Ireland (NI) as dictated by the Northern Ireland Protocol of the Withdrawal Agreement. Circuit-breakers placed on the NI market need to conform with the LVD and be CE marked.

2. TYPES OF CIRCUIT-BREAKER

BS EN 60898 series relate to low voltage circuit-breakers for use in household and similar installations such as offices, commercial and industrial premises, hospitals, public buildings, etc. In the UK these are traditionally known as miniature circuit-breakers or MCBs.

BS EN 60947-2 relate to low voltage circuit-breakers for use in industrial, large commercial and similar installations. These are traditionally known as Moulded Case Circuit-Breakers (MCCBs) or Air Circuit-Breakers (ACBs) according to their construction.

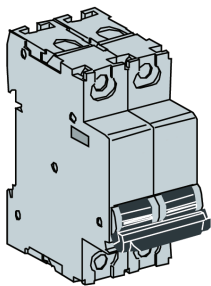

MCB

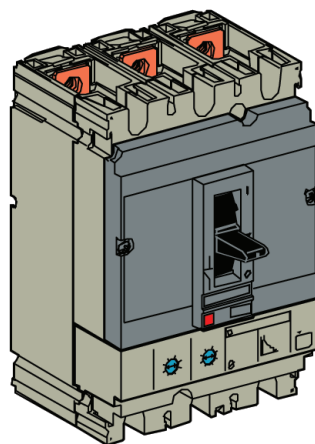

MCCB

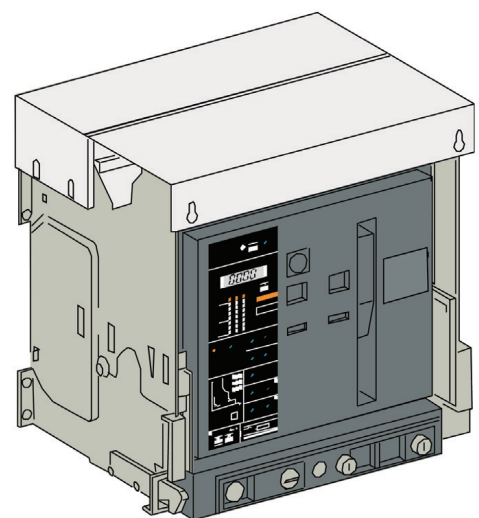

ACB

2.1. Miniature Circuit-Breakers (MCBs)

MCBs to BS EN 60898 series are suitable for operation by uninstructed persons (ordinary persons) and have fixed protection settings, generally a two position on/off switch and a performance relative to the final circuits in an electrical installation. MCBs would normally be the final overcurrent protection measure in the electrical system, for example before socket-outlets or lighting circuits.

BS EN 60898 series applies to circuit-breakers (MCBs) :

- designed for use by uninstructed persons
- with a rated voltage not exceeding 440 V AC or 1 000 V DC
- with a rated current not exceeding 125 A
- with a short-circuit capacity not exceeding 25 kA (AC) or 10 kA (DC)
- characteristic types B, C & D (application specific tripping characteristics may also be available)

MCBs may also be rated in accordance with BS EN 60947-2 for industrial or similar applications.

2.2. Moulded Case Circuit-Breakers (MCCBs)

MCCBs may have fixed or adjustable protection settings, normally a three position toggle operating handle giving on-off-tripped indication plus reset function, and a performance level relative to the incoming supply such that they can be installed at a point close to the supply transformer.

BS EN 60947-2 applies to circuit-breakers (MCCBs) :

- intended to be operated and installed by instructed or skilled persons
- with a rated voltage not exceeding 1 000 V AC or 1 500 V DC
- current ratings typically up to 1 600 A but may be up to 3 200 A
- short circuit ratings typically up to 100 kA

2.3. Air Circuit-Breakers (ACBs)

ACBs are normally used as the main incoming protection and have a spring-operated mechanism to open and close the device often charged by an internal motor. The protection settings may include time delays and the devices will have a short-time withstand value to give full discrimination under fault conditions with downstream protection devices.

BS EN 60947-2 applies to circuit-breakers (ACBs) :

- intended to be operated and installed by instructed or skilled persons
- with a rated voltage not exceeding 1 000 V AC or 1 500 V DC
- current ratings typically up to 6 300 A
- short circuit ratings typically up to 150 kA

3. LOW VOLTAGE CIRCUIT-BREAKERS FOR USE IN HOUSEHOLD AND SIMILAR INSTALLATIONS

3.1. History of the development of 60898

BS EN 60898-1, BS EN 60898-2 (EN 60898-1, EN 60898-2, IEC 60898-1 IEC 60898-2), BS IEC 60898-3

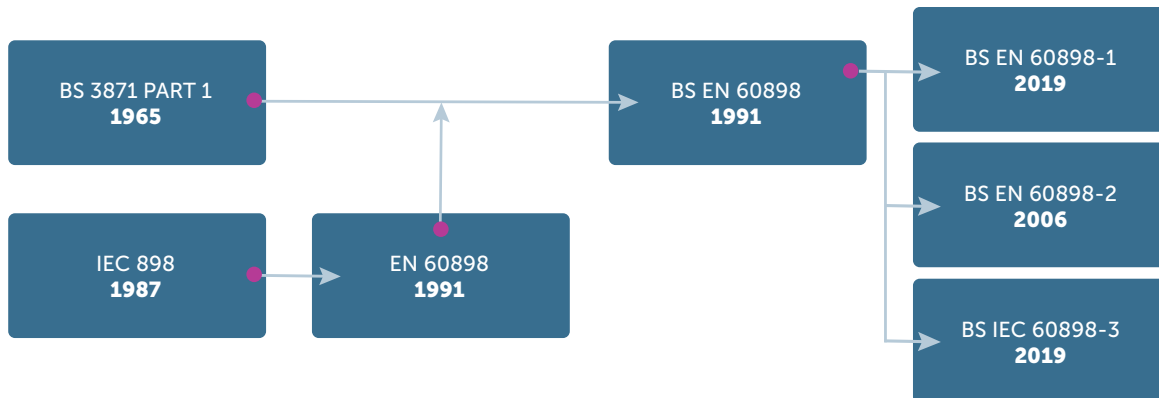

It can be seen from the diagram above that up to 1987 no IEC standard existed for miniature circuit-breakers that, in the UK, had been manufactured since 1965 to BS 3871, under the title 'Miniature Air Circuit-breakers for a.c. circuits.'

The introduction in 1987 of IEC 898, under the title 'Circuit-breakers for Overcurrent Protection for Household and Similar Installations', formed the basis for acceptance of the European Standard EN 60898; which was published in the UK in 1991, as BS EN 60898. BS 3871 Part 1 was withdrawn on the 1st July 1994.

Circuit-breakers that complied with BS 3871 Part 1 before 1st July 1994, as declared by the manufacturer, were allowed to apply for production until 30th June 1999. Since this date all products were expected to comply with BS EN 60898.

BS EN 60898 was further developed into parts:

- BS EN 60898-1 which gives the requirements for circuit-breakers rated for AC only
- BS EN 60898-2 which gives the requirements for circuit-breakers rated for both AC and DC.
- BS IEC 60898-3 which gives the requirements for circuit-breakers rated for DC only

NOTE: BS EN IEC 60898-3 was under development at the time of publication of this Guide.

3.2. BS EN 60898 Characteristics

3.2.1. Preferred values of current

The preferred values are 6, 8, 10, 13, 16, 20, 25, 32, 40, 50, 63, 80, 100 and 125A.

NOTE: MCBs with ratings below 6 A are commonly available.

3.2.2. Isolation

Circuit-breakers conforming to BS EN 60898 series are suitable for isolation. However, the earlier standard BS 3871 did not contain verification or marking requirements for isolation. Therefore, unless the manufacturer applied additional constructional requirements to BS 3871 circuit-breakers, these cannot be assumed to be suitable for isolation.

3.3. BS EN 60898 Time/Current Characteristics

3.3.1. Instantaneous Trip Characteristics to BS EN 60898 series

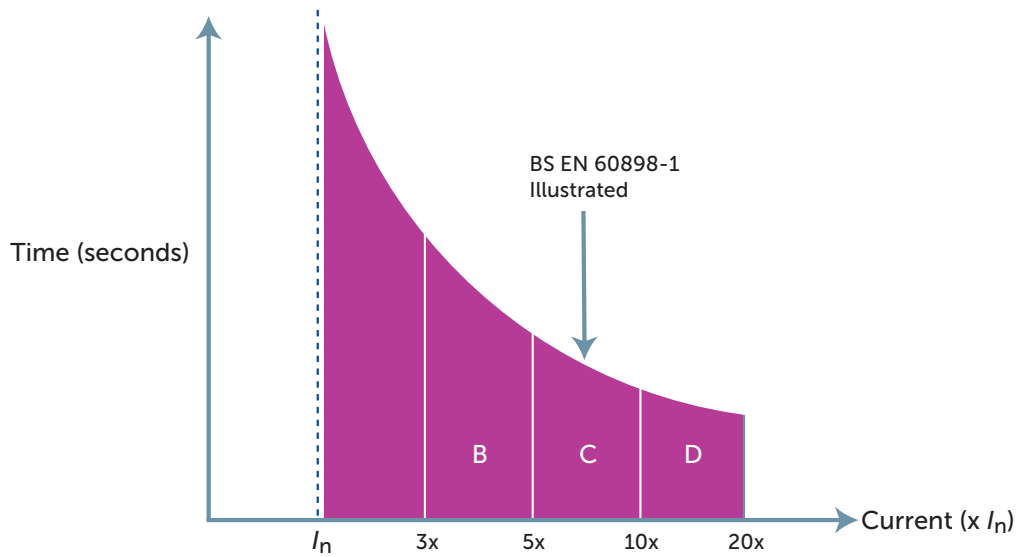

Trip Type	Range of instantaneous Trip (< 0.1 s)	Load Type	Typical Load (see manufacturer's data for application)
BS EN 60898-1 Range			
B	3 to $5I_n$	Resistive	Heaters, showers, cookers, socket outlets.
C	5 to $10I_n$	Inductive	Motors, general lighting circuits, power supplies.
D	10 to $20I_n$	High Inductive	Transformers, motors, discharge lighting circuits, computers.
<i>Note: There is no Type A instantaneous tripping characteristic to avoid confusion with the A abbreviation for amperes.</i>			
BS EN 60898-2 Range			
B	3 to $5I_n$ (AC) 4 to $7I_n$ (DC)	Resistive	Heaters, showers, cookers, socket outlets. Rail, battery systems, photovoltaic.
C	5 to $10I_n$ (AC) 7 to $15I_n$ (DC)	Inductive	Motors, general lighting circuits, power supplies. Rail, battery systems, welding equipment photovoltaic.
BS IEC 60898-3 Range			
B	4 to $7I_n$	Resistive	Rail, battery systems, photovoltaic.
C	7 to $15I_n$	Inductive	Rail, battery systems, welding equipment, photovoltaic.
BS3871 Range (Superseded)			
1	2.7 to $4I_n$	Resistive	Domestic, Heaters, Showers, Cookers, general socket outlets.
2	4 to $7I_n$	Resistive/Inductive	Small inductive switching loads, lighting and domestic circuits.
3	7 to $10I_n$	Inductive	Motors, general lighting circuits, power supplies.
4	10 to $50I_n$	High Inductive	Transformers, motors, discharge lighting circuits, computers.

3.4. BS EN 60898 – Rated Values

3.4.1. U_e Rated operational voltage

The nominal voltage of the system should not exceed U_e .

Example: Single Pole $U_e = 230/400$ V and for Three Pole $U_e = 400$ V

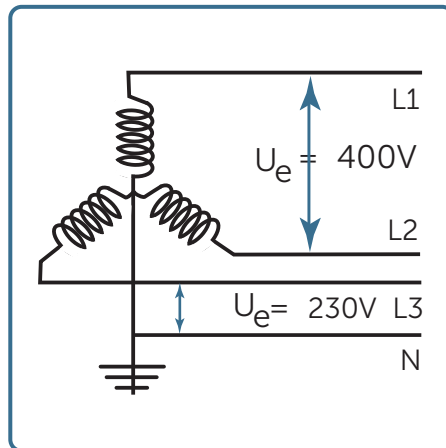

BS EN 60898 series declares that rated voltages of 230 V may be read as 240 V, accordingly the shortcircuit test recovery voltage is modified to cover up to 253 V.

3.4.2. U_i Rated Insulation Voltage

This is the voltage on which the dielectric properties are based using tests at high voltage and mains frequency.

Example: $U_i = 500$ V, test voltage = 2000 V

Unless otherwise stated the rated insulation voltage is the value of the maximum rated operational voltage of the circuit-breaker. In no case shall the maximum rated operational voltage exceed the rated insulation voltage.

3.4.3. U_{imp} Rated Impulse Withstand Voltage

This is the voltage on which clearance distances are based. This is a voltage impulse with a 1.2/50 μ s wave shape, see figure below.

Example: $U_{imp} = 4$ kV for 230/400V rated MCBs

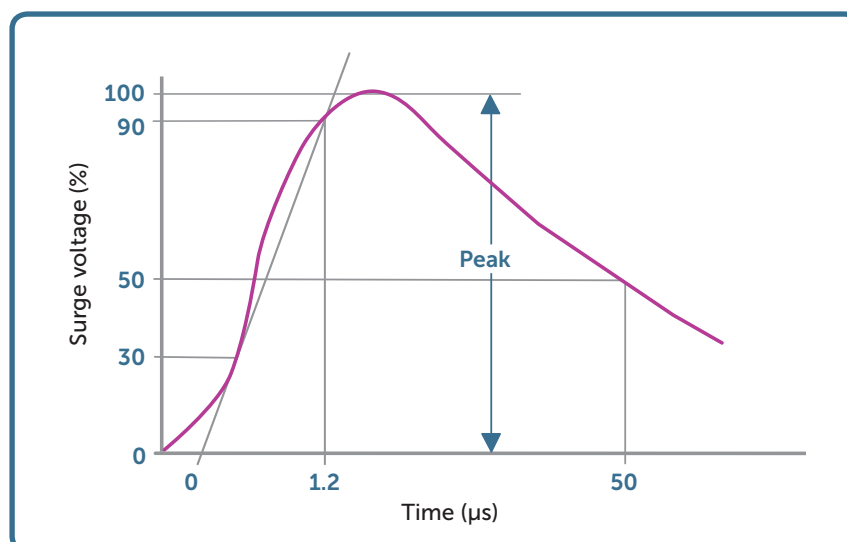

3.4.4. I_n Rated Current

The current that the circuit-breaker will carry continuously under specified conditions and on which the time/current characteristics are based.

Unless otherwise stated I_n is based on a reference ambient temperature of 30°C.

Example $I_n = 32A$ rating, type C marked 'C32'.

3.4.5 I_{cn} Rated Short-Circuit Capacity

The manufacturer must declare the short-circuit capacity of the circuit-breaker. The preferred short-circuit capacities up to 25 kA are recognised with the following values of I_{cn} see table below.

The short-circuit capacity according to BS 3871, now superseded, was expressed as an 'M' value see table below.

Standard values of short-circuit capacity I_{cn}	
BS EN 60898	
Marking	I_{cn} Amperes
1500	1500
3000	3000
4500	4500
6000	6000
10000	10000
15000	15000
20000	20000
25000	25000

Short-circuit capacity according to BS 3871	
BS 3871 (Superseded, withdrawn)	
M1	1000 A
M1.5	1500 A
M3	3000 A
M4.5	4500 A
M6	6000 A
M9	9000 A

The prospective fault current at the incoming terminals of the circuit-breaker should not exceed I_{cn} except that the prospective fault current may exceed I_{cn} when co-ordinated with another short-circuit protective device as specified by the manufacturer.

In order to define the value of I_{cn} the circuit-breakers under test must be subjected to a test sequence of:

$$I_{cn} = O - t - CO$$

Where:

- O = opening operation under fault conditions.
- t = time interval before re-closing (3 minutes.)
- C = closing operation on to a fault.

After this test sequence, leakage current, dielectric and overcurrent release tests are applied.

3.4.6. I_{cn1} Rated making and breaking capacity of an individual pole

The value of limiting short-circuit making and breaking capacity of each individual pole of a multipole circuit breaker.

In order to define the value of I_{cn1} the circuit-breakers under test must be subjected to a test sequence of:

$$I_{cn1} = O - t - CO$$

Where:

- O = opening operation under fault conditions.
- t = time interval before re-closing (3 minutes.)
- C = closing operation on to a fault.

After this test sequence, leakage current, dielectric and overcurrent release tests are applied.

3.4.7. I_{cs} Service Short-Circuit Capacity [Not marked on the circuit-breaker]

In order to define the value of I_{cs} the circuit-breakers under test must be subjected to a test sequence of three short-circuit operations:

$$I_{cs} = O - t - CO - t - CO$$

Where:

- O = opening operation under fault conditions.
- t = time interval before re-closing (3 minutes)
- C = closing operation on to a fault.

After this test sequence, leakage current, dielectric, and time/current characteristics tests are applied. The circuit-breaker must meet certain test parameters to ensure that the circuit-breaker has not deteriorated in performance and can, in fact, be put back into service.

I_{cn}	K
≤ 6000	1
$\leq 6000 < 10000$	0.75 ¹
< 10000	0.5 ²
¹ Minimum value of I_{cs} 6000 A	
² Minimum value of I_{cs} 7500 A	

Ratio (K) between service short-circuit capacity (I_{cs}) and rated short-circuit capacity (I_{cn})

3.4.8. Energy-Limiting Classes

Circuit-breakers to BS EN 60898 of B-type and C-type, having rated current up to and including 63 A and a rated short-circuit capacity of 3 000 A, 4 500 A, 6 000 A and 10 000 A, are classified according to the limits within which their I^2t characteristics lie. I^2t is proportional to the energy let-through by the circuit-breaker under short-circuit conditions.

This classification is indicated on the circuit-breaker as shown below.



Circuit-breakers are classified into energy limiting classes in order to help the project engineer and installer to obtain selectivity with devices on the supply side and determine cable protection in the case of a fault current (short-circuit).

3.4.9. Permissible I^2t (let-through energy) in A^2s for circuit-breakers type B with rated current up to and including 63A

	Type B				
Rated short-circuit capacity A	Class 1	Class 3			
	≤ 63A	≤ 16A	20 A 25 A 32 A	40 A	50A 63A
3 000	No limits specified	15 000	18 000	21 600	28 000
4 500		25 000	32 000	38 400	48 000
6 000		35 000	45 000	54 000	65 000
10 000		70 000	90 000	108 000	135 000

3.4.10. Permissible I^2t (let-through energy) in A^2s for circuit-breakers type C with rated current up to and including 63A

	Type C				
Rated short-circuit capacity A	Class 1	Class 3			
	≤ 63A	≤ 16A	20 A 25 A 32 A	40 A	50A 63A
3 000	No limits specified	17 000	20 000	24 000	30 000
4 500		28 000	37 000	45 000	55 000
6 000		40 000	52 000	63 000	75 000
10 000		80 000	100 000	120 000	145 000

The maximum let through energy values are given in the tables above. The manufacturer may publish data giving actual let-through energy values which may be lower than the maximum values.

Let-through energy characteristics for all other circuit-breakers including Type D and Class 1 are available from the manufacturer.

3.5 Installation Factors

3.5.1. Application of an RCBO to BS EN 61009

An RCBO will have overcurrent characteristics as for the equivalent MCB (see above) and will also have residual current characteristics.

Where the RCD characteristic is used to satisfy the automatic disconnection requirements of BS 7671, the maximum values of earth fault loop impedance in Table 41.5 of BS 7671 may be used.

The selection of the type of overcurrent characteristic (B, C or D) is made as for the equivalent MCB, according to the application.

3.5.2. Protection against electric shock – Automatic disconnection in case of a fault – determination of maximum earth-loop impedance (Z_s)

The maximum value of earth fault loop impedance may be found in the IET Wiring Regulations (BS 7671) for Type B, C and D circuit-breakers, or from details published by the manufacturer.

For superseded BS 3871 (Types 1, 2, 3 and 4) the maximum value of earth fault loop impedance may be calculated using the formula in the regulations BS 7671 and the manufacturer's tripping characteristic.

Where the requirements cannot be achieved using an overcurrent protective device (OCPD) alone, the use of a residual current device may be used to provide protection against shock due to an earth fault condition. This can be achieved using a device complying with BS EN 61008 or BS EN 61009. At the design stage of the installation, the earth fault loop impedance (Z_s) and the load characteristic may determine the type of circuit-breaker used.

3.5.3. Fault current (short-circuit) protection of cables

The application of fault current protective devices to cable protection is detailed in BS 7671 and is given by:

$$I^2t \leq k^2S^2$$

Where:

I^2t is the energy let-through value of the protective device

k^2S^2 is the energy withstand of the cable

3.5.4. Back-up protection – general

BS 7671 permits the breaking capacity of a circuit-breaker to be less than its associated prospective fault current when back-up protection is employed. Back-up is also referred to as cascading. Back-up protection consists of an upstream short-circuit protective device (SCPD) that helps a downstream circuit-breaker to break fault currents greater than its maximum breaking capacity I_{cn} for an MCB, which in effect is a conditional rating, see Figure A below.

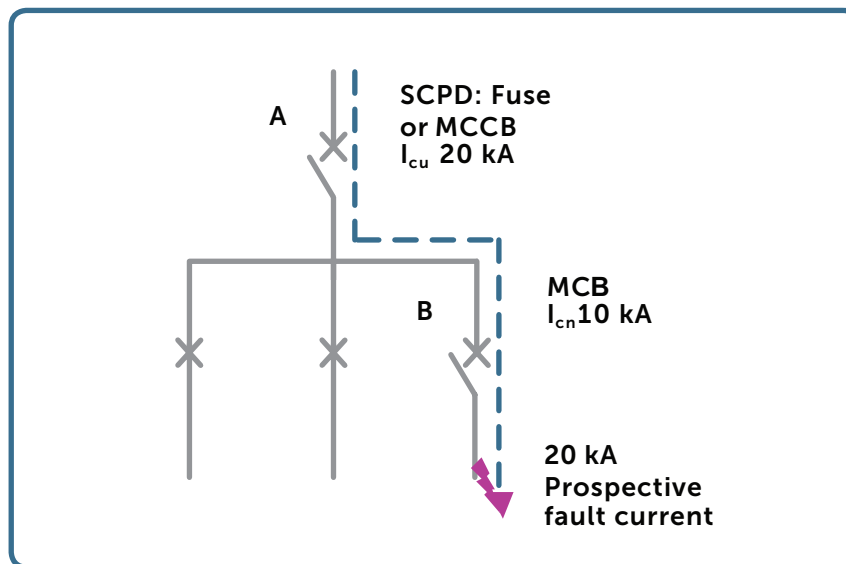

Figure A. Example of backup protection

Circuit-breaker product standards prescribe back-up protection requirements, which can only accurately be verified by test. The energy let-through (proportional to I^2t) of the back-up combination, when required, must be derived from testing and obtained from the manufacturer.

3.5.5. Back-up protection (combined short-circuit protection) methodology

Circuit-breaker standards use the term 'back-up protection' whereas BS 7671 uses the term 'combined short-circuit protection' to describe the overcurrent coordination in short-circuit conditions of two overcurrent protective devices (OCPDs) in series, resulting in a combined short-circuit current capability higher than one OCPD alone.

Desk top studies frequently indicate that back-up coordination requires the upstream SCPD to independently limit the energy let-through and peak current, to values that can be withstood by the downstream SCPD, assuming that the downstream SCPD makes no contribution to the fault interruption process. This approach errs on the side of caution in relation to device coordination and cable protection studies.

However, where an MCCB, MCB or fuse is the upstream SCPD, and the downstream SCPD is an MCB, coordination tests can be used to validate that the I^2t of the specific combination will not exceed the I^2t value of the downstream MCB at its maximum breaking capacity.

This reduction in the energy let-through is a result of having two protective devices interrupting the fault current and thus creating superior current limitation and arc extinction than the individual upstream SCPD "A" alone, this is illustrated in Figure B below.

Back-up protection can also be achieved by coordinating the upstream circuit-breaker contacts to separate momentarily with the downstream circuit-breaker. This arrangement allows the upstream device to return to the closed position, having assisted the downstream circuit-breaker to interrupt the fault current.

3.5.6. Consumer Unit fuse conditional rating

Fuse back-up protection to 16 kA is a mandatory test for protective devices in Consumer Units complying with BS EN 61439-3 Annex ZB (previously BS EN 60439-3 Annex ZA.) This is a conditional rating, as the conditions specifically relate to the use of an upstream BS 88-3 (formerly BS 1361) 100 A fuse.

3.5.7. Cable protection in the case of back-up protection

In Figure B below the I^2t of the upstream SCPD "A" and downstream MCB "B" operating together at 20 kA, will be equal to or less than the I^2t of MCB "B" at 10 kA. The I^2t to be used in the conductor fault current assessment would be that of MCB "B" at 10 kA. This combination has to be confirmed by the manufacturer, together with the maximum prospective fault current applicable.

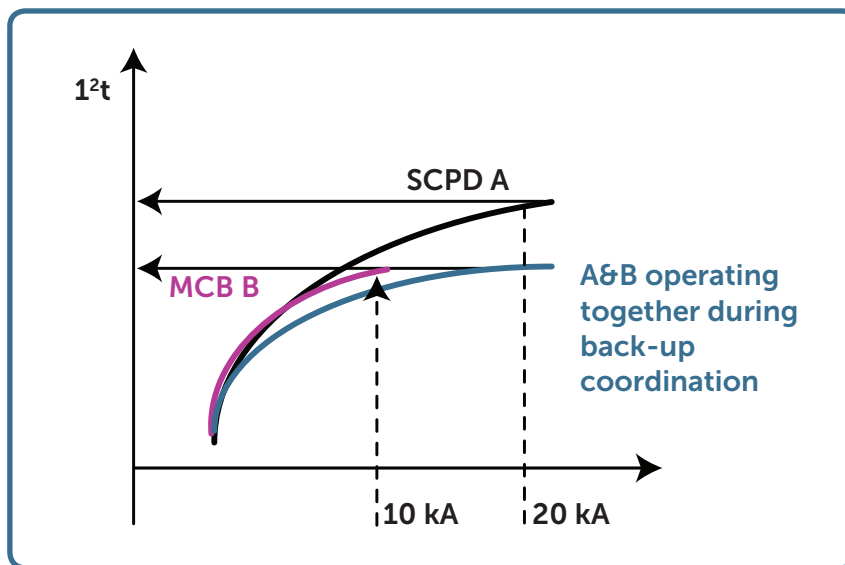

Figure B. Example of I^2t

3.5.8. Low voltage switchgear and controlgear assemblies

The assembly manufacturer is responsible for ensuring the short-circuit capability of the equipment between the incoming and outgoing terminals of the assembly (incoming and outgoing devices, busbars, connections, etc.). The short-circuit rating is determined in accordance with the applicable product standard and stated by the manufacturer.

LV assemblies are commonly known as: Consumer Units, Distribution Boards, Panelboards, Switchboards and Motor Control Centres.

3.5.9. Harmonic currents

Harmonic currents are those in which the nature of the load distorts the current waveform, generally due to electronic control of the current e.g. electronic ballasts in lighting; power supplies in computers.

Harmonics are expressed as a multiple of the mains frequency (50Hz in the UK) e.g. the 3rd harmonic has a frequency of $3 \times 50 = 150$ Hz.

There are two factors to be considered relative to circuit-breakers:-

3.5.9.1 Overload protection

Circuit-breakers with bimetallic thermal overload protection use a trip release that responds to the heating effect of the overload current i.e. they respond to the true RMS value of the current waveform. This type of circuit-breaker will provide protection to the circuit conductors in the case of overload currents including harmonics.

3.5.9.2 Neutral currents

3.5.9.2.1.

Third harmonics and their multiples in a 3-phase system accumulate in the neutral conductor, even when the load currents in the phases are balanced. This needs to be allowed for in the sizing of the neutral in equipment and conductors.

3.5.9.2.2

BS 7671 regulation 523.6.3 states "If the total harmonic distortion due to third harmonic currents or multiples of the third harmonic is greater than 15% of the fundamental line current the neutral conductor shall not be smaller than the line conductors". In the case of significant neutral currents due to harmonics a 4-pole circuit-breaker with a protected neutral pole may be required to protect the neutral conductor.

FURTHER TECHNICAL AND APPLICATIONS INFORMATION, COMMON TO ALL LV CIRCUIT-BREAKERS, IS GIVEN IN SECTION 5.

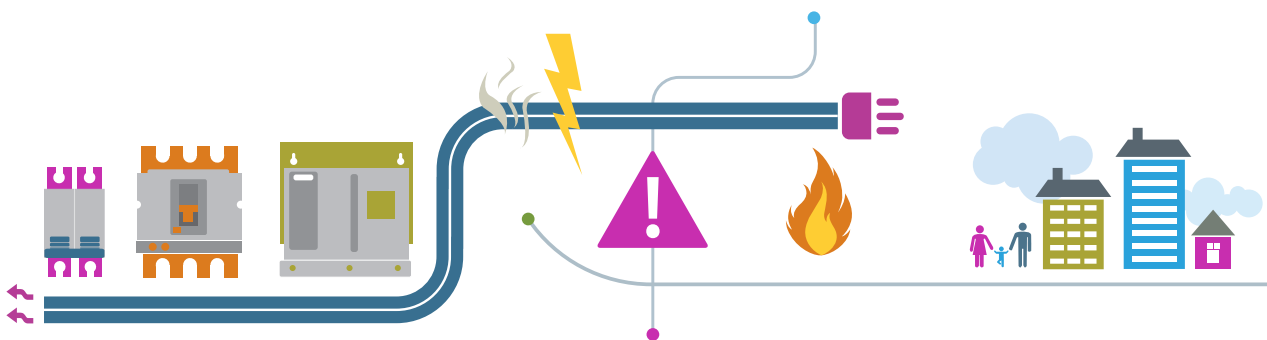

4. LOW VOLTAGE-CIRCUIT-BREAKERS FOR USE IN INDUSTRIAL AND SIMILAR INSTALLATIONS

4.1. History of the development of 60947-2

BS EN 60947-2 (EN 60947-2, IEC 60947-2)

To fully understand the scope of IEC 60947-2, one must refer back to the origins of circuit-breaker standards. The original standard in the UK was BS 3871 Part 2 1966, which was followed by the evolution of IEC 157 Part 1 1973. This was incorporated as BS 4752 in 1977. During the 1980's the concept of the IEC 947 series of standards evolved. This for the first time would bring all products relating to *low voltage switchgear and control gear under one generic standard.

*Low voltage is defined as up to 1000V a.c. or 1500V D.C.

IEC 60947 Series – Specifications for low voltage switchgear and control gear

Standard	Title / Product
IEC 60947-1 ¹	General Rules
IEC 60947-2	Circuit-breakers
IEC 60947-3	Switches, disconnectors, switch disconnectors and fused combination units
IEC 60947-4 series	Contactors and motor starters
IEC 60947-5 series	Control circuit devices
IEC 60947-6 series	Multiple function switching devices
IEC 60947-7 series	Ancillary equipment e.g. terminals
IEC 60947-8	Control units for built-in thermal protection (PTC) for rotating electrical machines
IEC 60947-9 series	Active arc-fault mitigation systems

¹ Products must comply with the relevant standard listed in this Table. General Rules is a reference for the product standards and no product should be claimed to comply with IEC 60947-1.

In 1989 the International standard for air circuit-breakers IEC 157 was superseded by IEC 947-2. This was adopted as the European norm EN 60947-2 in March 1991. This was published in the UK as British Standard BS EN 60947-2 in May 1992 with the withdrawal of the dual standard IEC 157/BS 4752 in September 1992.

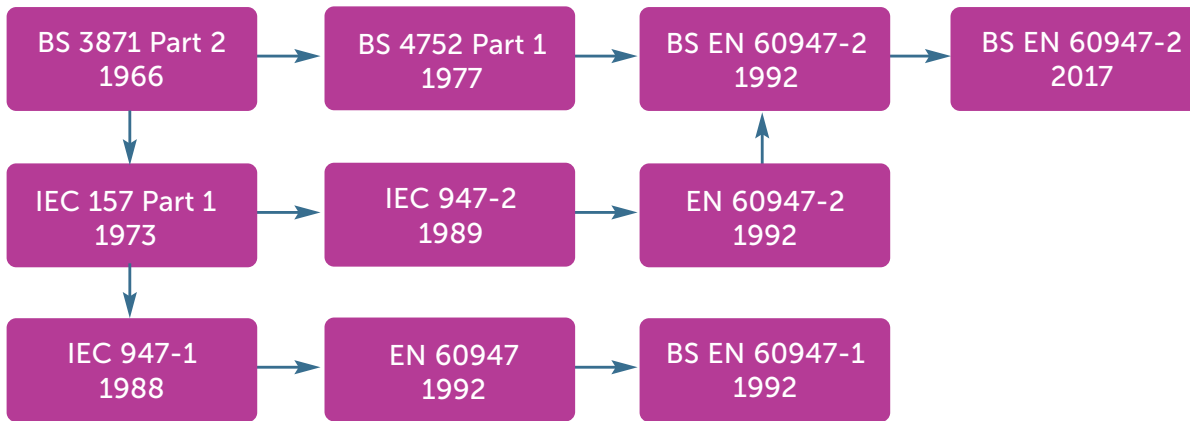

Circuit-breakers that complied with the relevant national standard before 30th September 1992, as declared by the manufacturer or by certification, were allowed to apply for production until September 1997. Since this date, all circuit-breakers must comply with the current edition of BS EN 60947-2.

4.2. BS EN 60947-2 Characteristics

4.2.1. Isolation

BS EN 60947-2 is precise in its requirements for circuit-breakers suitable for isolation by defining tests to which such units must comply. If the criteria for such tests are met the product must, if intended for use as an isolator, display the symbol illustrated below.



4.2.2. Selectivity Categories

BS EN 60947-2 recognises a classification according to the provision of time-delayed selectivity.

4.2.2.1 Selectivity Category A

Designates circuit-breakers not specifically intended for selectivity with devices on the load side. In other words, circuit-breakers will be selective only up to certain fault levels, above which selectivity with devices on the load side cannot be guaranteed.

4.2.2.2 Selectivity Category B

Designates circuit-breakers specifically intended for selectivity with devices on the load side. Such circuit-breakers will incorporate some form of time delay.

Typical time current curve for an MCCB with an electronic tripping unit

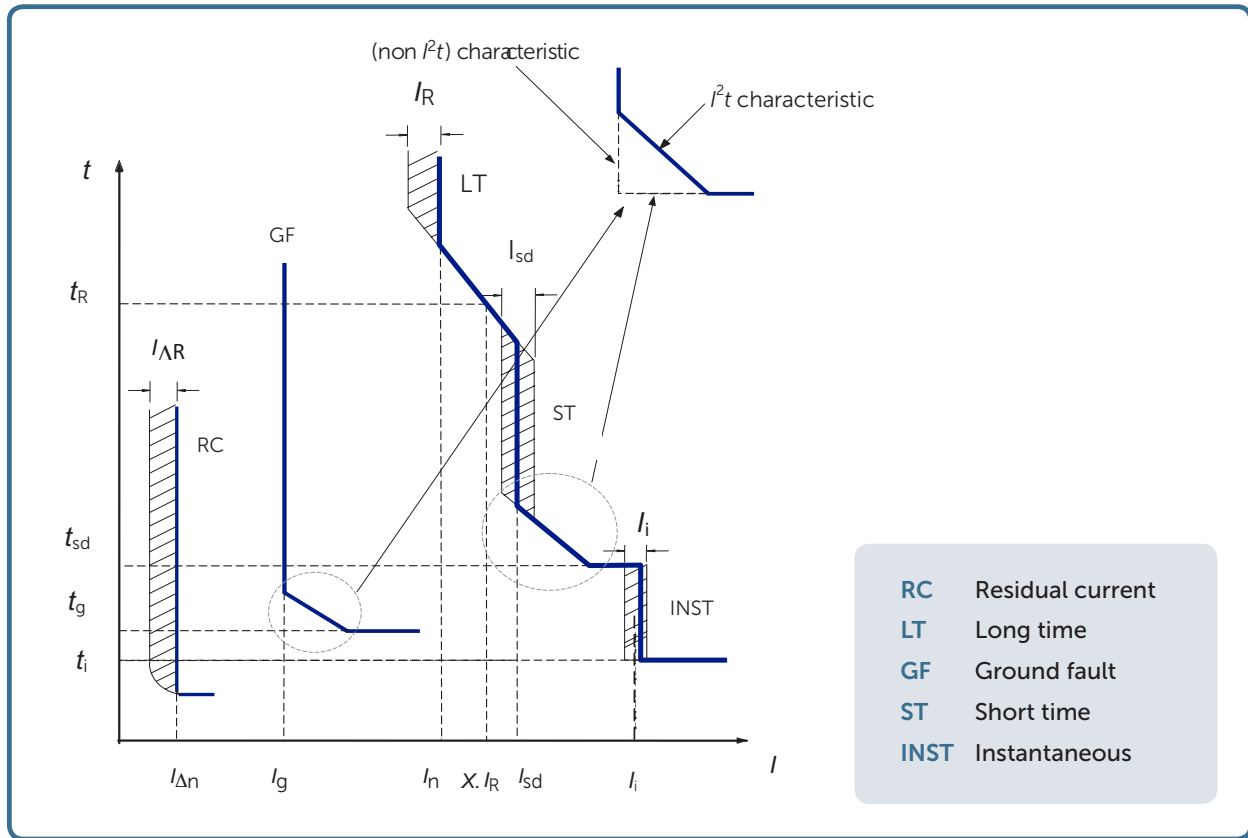

Typical time current curve for an MCCB with a thermal/magnetic tripping unit

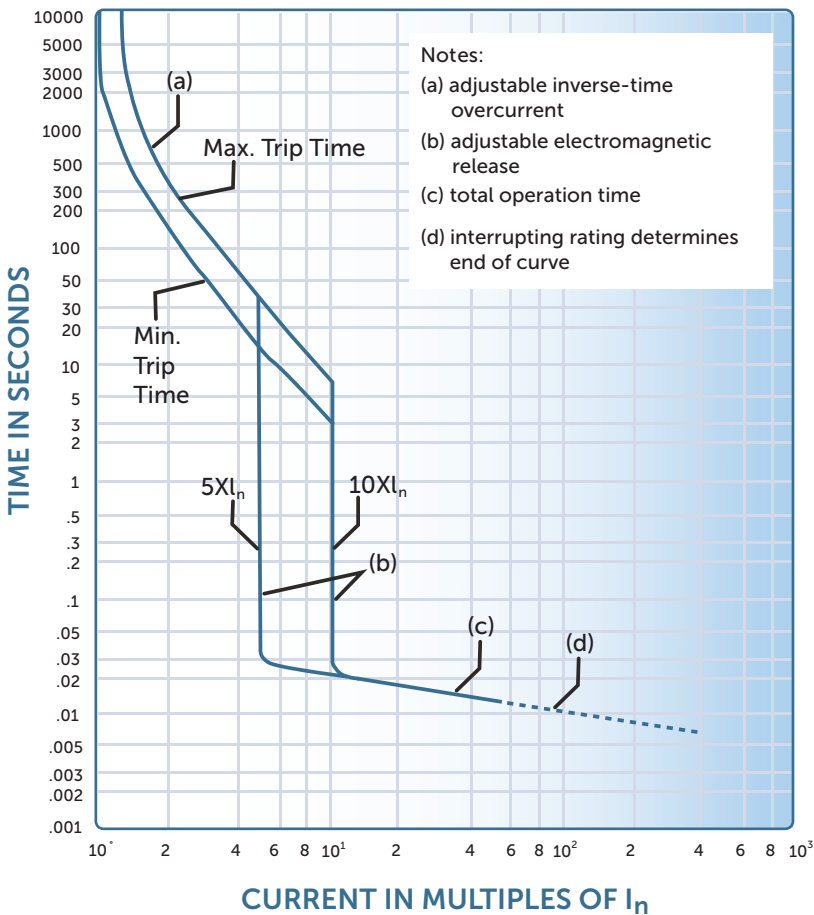

4.3. BS EN 60947-2 – Rated Values

4.3.1. U_e Rated operational voltage

The nominal line-to-line voltage of the system should not exceed U_e

In IEC Publication 60038 the voltage values of 230 V and 230/400 V have been standardised. These values have progressively replaced the values of 240 V, 220/380 V and 240/415 V.

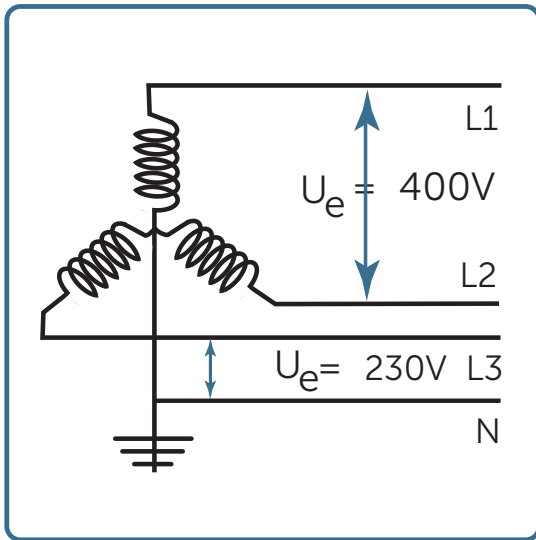

4.3.2. U_i Rated Insulation Voltage

The rated insulation voltage of a circuit-breaker is the value of voltage, assigned by the manufacturer, to which dielectric tests and creepage distances are referred.

Unless otherwise stated the rated insulation voltage is the value of the maximum rated operational voltage of the circuit-breaker. In no case shall the maximum rated operational voltage exceed the rated insulation voltage.

4.3.3. U_{imp} Rated Impulse Withstand Voltage

The peak value of an impulse voltage of prescribed form and polarity which the circuit-breaker is capable of withstanding without failure under specified conditions of test and to which the values of the clearances are referred.

It is the value of transient peak voltage the circuit-breaker can withstand from switching surges or lightning strikes imposed on the supply.

Example. $U_{imp} = 8kV$, Tested at 8 kV peak with 1.2/50 μs impulse wave, as shown below:

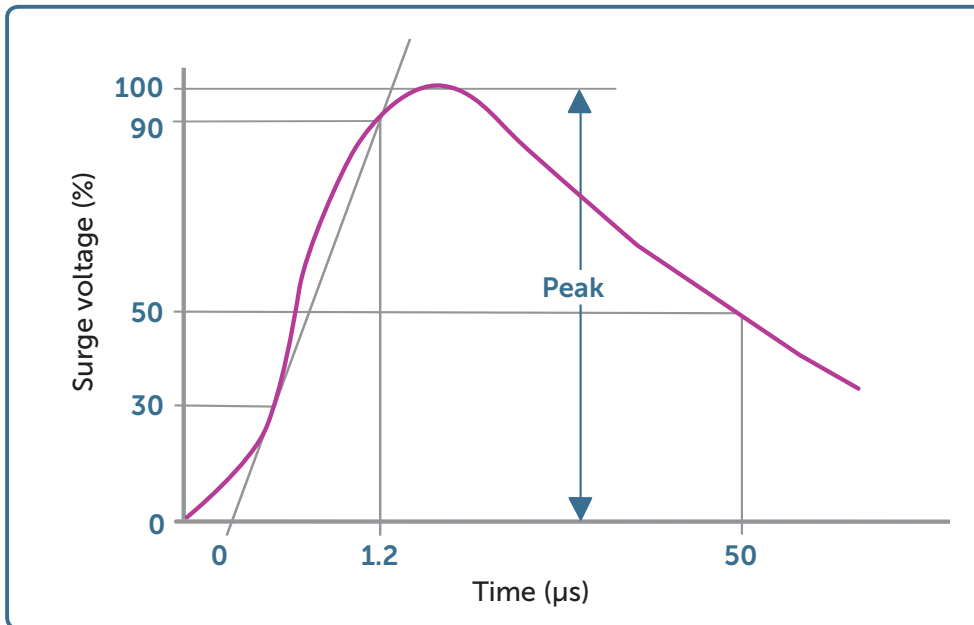

4.3.4. I_n Rated Current

The current that the circuit-breaker will carry continuously under specified conditions and on which the time/current characteristics are based.

Unless otherwise stated I_n is based on a reference ambient temperature of 30 °C.

4.3.5. Short Circuit-breaking Capacities

BS EN 60947-2 recognises both a rated ultimate (I_{cu}) and a rated service (I_{cs}) short circuit-breaking capacity for both selectivity category A and selectivity category B circuit-breakers.

4.3.6. I_{cu} Rated Ultimate Short-circuit Breaking Capacity

In order to define the value of I_{cu} the circuit-breakers under test must be subjected to a test sequence of:

$$I_{cs} = O - t - CO$$

Where:

- O = opening operation under fault conditions.
- t = time interval before re-closing (not less than 3 mins.)
- C = closing operation on to a fault.

After this test sequence, dielectric and overcurrent release tests are applied.

4.3.7. I_{cs} Rated Service Short-circuit Breaking Capacity

In order to define the value of I_{cs} the circuit-breakers under test must be subjected to a test sequence of:

$$I_{cs} = O - t - CO - t - CO$$

Where:

- O = opening operation under fault conditions.
- t = time interval before re-closing (not less than 3 minutes)
- C = closing operation on to a fault.

After this test sequence, load-switching, dielectric, terminal temperature and overcurrent release tests are applied. The circuit-breaker must meet certain test parameters to ensure that the circuit-breaker has not deteriorated in performance and can, in fact, be put back into service.

4.3.8. Application of Breaking Capacities

The rated service short circuit-breaking capacity (I_{CS}) applies to short-circuit faults that could occur in practice, whereas the rated ultimate short-circuit-breaking capacity (I_{CU}) is the maximum theoretical fault value of the installation at the point of connection.

Thus a circuit-breaker can remain in service after interrupting a short-circuit up to its rated value of I_{CS} . Where two or more faults occur between the I_{CS} and I_{CU} values, the continued operation of the circuit-breaker must be verified.

I_{CS} may be expressed as a value of current or a percentage of I_{CU} . I_{CS} must be at least 25% of I_{CU} .

The calculated prospective fault current at the incoming terminals of the circuit-breaker should not exceed I_{CU} . Exception: Using back up protection as specified by the manufacturer.

4.3.9. Energy let-through (I^2t)

Energy let-through is not a rated value but is used in the consideration of back-up and selectivity. I^2t is proportional to the energy let-through by the circuit-breaker under short-circuit conditions. I^2t is used at fault current levels where the short time to operate does not lend itself to the use of time current curves.

Certain circuit-breakers now come with the additional functionality to reduce the tripping time and hence the energy let-through, which can be activated under certain maintenance procedures to improve safety to the user/assembly in the event of a short-circuit fault.

Likewise, some electronic trip units use predictive maintenance to alert the user, based on the service events it has experienced to indicate renewal is necessary.

4.3.10. I_{CW} Rated Short-Time Withstand Current

Circuit-breakers of Selectivity Category B have a short-time delay (STD) allowing time-graded selectivity between circuit-breakers in series.

I_{CW} is the fault current the circuit-breaker will withstand for the maximum short-time delay time.

Preferred times are: 0.05, 0.1, 0.25, 0.5 and 1.0 second.

Example:

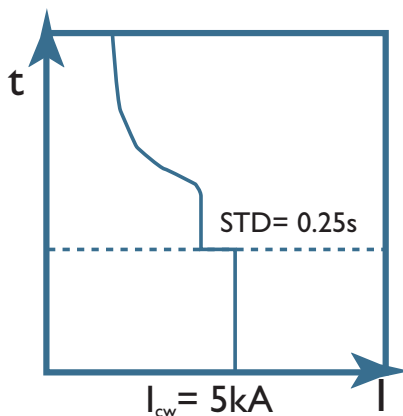

4.3.11. BS EN 60947-2 Additional Functions

Specific functions provided by some circuit-breakers are covered in a number of annexes to BS EN 60947-2. Circuit-breakers with all or some of these additional functions need to comply with both the main body of the standard and the relevant annex.

Annexes of circuit-breaker specific functions

Annex	Subject	Acronym
B	Circuit-breakers incorporating residual current protection (RCD function) for RCD Types AC, A and B.	CBR
F	Circuit-breakers with electronic overcurrent protection.	-
L	Circuit-breakers without overcurrent protection. (Used for isolation and switching).	CBI
M	Modular residual current devices. A modular arrangement of devices, some remote, arranged to switch-off a circuit-breakers under earth fault conditions.	MRCD
O	Instantaneous trip circuit-breakers (without overload releases). Principally coordinated with motor starters for short-circuit protection.	ICB
P	DC circuit-breakers for use in photovoltaic (PV) applications.	-
R	Circuit-breakers incorporating residual current protection with automatic re-closing functions.	-

4.4. Installation Factors

4.4.1. BS EN 60947-2 Overcurrent Co-ordination

Annex A of BS EN 60947-2 gives the principles of back-up protection and selectivity (discrimination) applied to circuit-breakers. The tests therein permit the manufacturer to establish enhanced short-circuit ratings for circuit-breakers in series or when backed-up by fuses. In addition the limits of selectivity between circuit-breakers in series may be established. The data obtained is published in the manufacturer's literature.

Additional information on the principles of back-up and selectivity, as applied to all low voltage equipment, is available in BSI publications PD IEC TR 61912-1 and PD IEC TR 61912-2.

4.5. Determination of maximum earth-loop impedance (Z_s)

In order to provide protection against electric shock in accordance with BS 7671, it is necessary to determine the maximum value of Z_s that will give the required disconnection time.

In the case of circuit-breakers to BS EN 60898-1 and fuses, Z_s is tabulated in the Wiring Regulations. This is possible because these devices have standardised, fixed, characteristics common to all such devices.

In the case of circuit-breakers to BS EN 60947-2 the characteristics are not standardised and, in most cases, are adjustable. In addition, circuit-breakers with electronic trip units may have adjustable time-delay and curve-shaping features. These features enhance the ability to provide circuit protection and co-ordination of devices. However the selected settings must then be applied to the determination of Z_s .

In this case Z_s is determined from the basic equation:

$Z_s I_a \leq U_o C_{\min}$ – which transposes to:

$$Z_s \leq \frac{U_o C_{\min}}{I_a}$$

where:

U_o is the nominal voltage to earth.

I_a is the current required to achieve the disconnection time as given in the Regulations.

C_{\min} is the minimum voltage factor to take account of voltage variations depending on time and place, changing of transformer taps and other considerations.

NOTE: For a low voltage supply given in accordance with the Electricity Safety, Quality and Continuity.

Regulations 2002 as amended, C_{\min} is given the value 0.95.

In determining I_a from the tripping characteristic, any applicable tolerances must be taken into account and the maximum value of I_a used. In general the tolerance band for the inverse time/current portion of the curve is given (see example below) and no further allowance needs to be made. In the case of the instantaneous (< 0.2 s) operating portion of the curve e.g. an electromagnetic release, the standard tolerance is $\pm 20\%$ of the current. The manufacturer may alternatively state a lower tolerance. Example: Using the typical characteristic curves illustrated on page 23.

Note that the current axis is in multiples of I_n (rated current) allowing the use of the same characteristic for different ratings.

Assume a rating of $I_n = 100$ A and $U_o = 230$ V with an electromagnetic release setting of $7.5 \times I_n = 750$ A.

It can be seen that for both a 0.4 second disconnection time and a 5 second disconnection time the inverse time/current curve is too slow and the electromagnetic release must be used. Thus, applying the tolerance of + 20%:-

$$Z_s \leq \frac{230 \times 0.95}{750 \times 1.2} = 0.24 \text{ ohms}$$

Typical time/Current characteristic for a thermal/magnetic MCCB

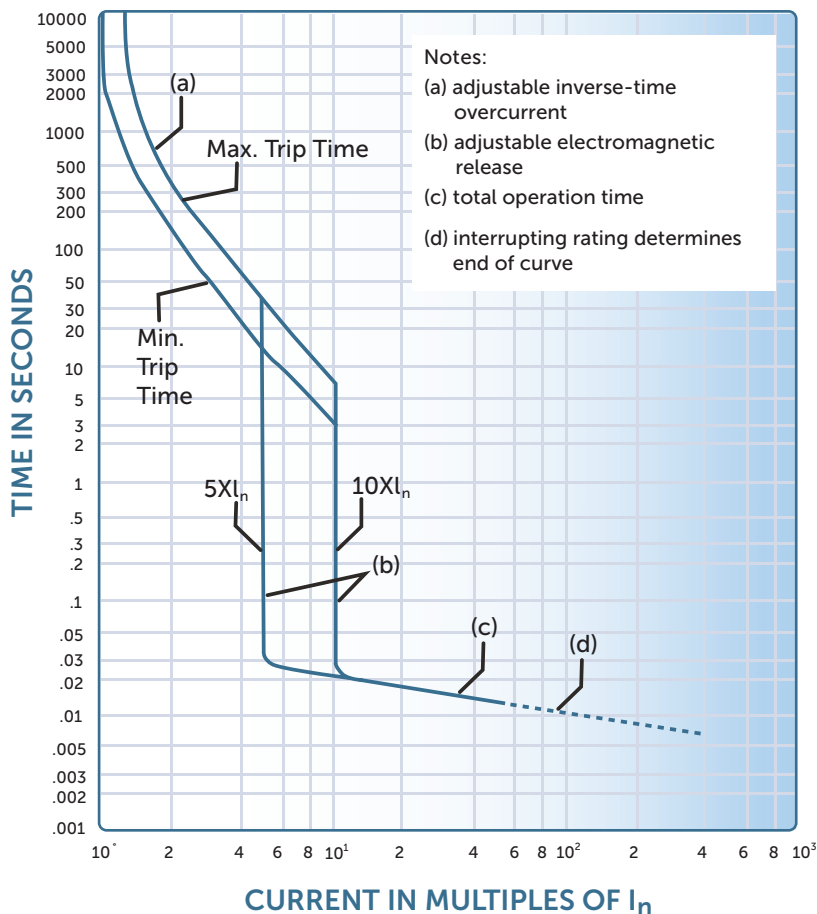

4.6 Harmonic Currents

Harmonic currents are those in which the nature of the load distorts the current waveform, generally due to electronic control of the current e.g. electronic ballasts in lighting; inverter drives, UPS systems.

Harmonics are expressed as a multiple of the mains frequency (50Hz in UK) e.g. the 3rd harmonic has a frequency of $3 \times 50 = 150$ Hz.

There are a number of factors to be considered relative to circuit-breakers:-

4.6.1. Overload protection

Circuit-breakers with bimetallic thermal overload protection use a trip release that responds to the heating effect of the overload current i.e. they respond to the true RMS value of the current waveform. This type of circuit-breaker and circuit-breakers with electronic overcurrent protection conforming to Annex F of BS EN 60947-2 will provide protection to the circuit conductors in the case of overload currents including harmonics.

4.6.2. Neutral currents

Third harmonics and their multiples in a 3-phase system accumulate in the neutral conductor, even when the load currents in the phases are balanced. This needs to be allowed for in the sizing of the neutral in equipment and conductors.

BS 7671 regulation 523.6.3 states "If the total harmonic distortion due to third harmonic currents or multiples of the third harmonic is greater than 15% of the fundamental line current the neutral conductor shall not be smaller than the line conductors".

In the case of significant neutral currents due to harmonics a 4-pole circuit-breaker with a protected neutral pole may be required to protect the neutral conductor.

4.6.3. Unwanted operation due to harmonic currents

Circuit-breakers with electronic overcurrent protection conforming to Annex F of BS EN 60947-2 have immunity to unwanted operation in the presence of specific percentages of odd harmonic currents.

Note: Conformity to Annex F of BS EN 60947-2 is indicated by either marking 'RMS.' on the circuit-breaker or is given in the manufacturer's literature or both.

5. TECHNICAL AND APPLICATION DATA – LOW VOLTAGE CIRCUIT-BREAKERS TO BS EN 60898 SERIES AND BS EN 60947-2

5.1. Circuit-breaker substitution in assemblies

BEAMA warns against the practice of installing circuit-breakers (e.g. MCCBs, MCBs) of one manufacturer as replacements or substitutions for devices of another manufacturer, without the necessary verification of performance. See BEAMA Technical Bulletin on safe selection of devices for installation in assemblies available on the BEAMA website.

LV assemblies such as Consumer Units, Distribution Boards, Panelboards, Switchboards and Motor Control Centres are verified with specific devices installed; these devices are more often than not from the same manufacturer as the assembly. Verification will have been undertaken, by the ASSEMBLY manufacturer, to BS EN 61439-2 or BS EN 61439-3 (formerly BS EN 60439-1 and BS EN 60439-3 respectively).

Substituting devices not verified by the assembly manufacturer invalidates any testing/verification and warranty.

BS 7671 places specific responsibilities on the installer; regulation 536.4.203 prescribes specific requirements for the integration of devices and components. Furthermore, regulation 510.3 requires that the installer takes into account the manufacturer's instructions in regard to devices fitted. If these regulations are not applied there is a probability that, in the event of accident, a fire or other damage, the installer would be accountable under Health and Safety legislation.

Although devices from different manufacturers may appear similar, the technical performance, dimensions, and terminations are not necessarily compatible. Manufacturer's instructions must always be followed.

5.2. Functional switching with circuit-breakers

Circuit-breakers and RCBOs are primarily circuit-protective devices and, as such, their related product standards do not intend them to be used as functional switches.

5.3. Coordination of Low voltage Switchgear and Controlgear assemblies with conductors operating at a temperature exceeding 70°C e.g. XLPE

BS 7671 regulation 512.1.5 requires that "Switchgear, protective devices, accessories and other types of equipment shall not be connected to conductors intended to operate at a temperature exceeding 70°C at the equipment in normal service, unless the equipment manufacturer has confirmed that the equipment is suitable for such conditions".

BS 7671 regulation; 523.1 (note b) requires that "Where a conductor operates at a temperature exceeding 70°C, it shall be ascertained that the equipment connected to the conductor is suitable for the resulting temperature at the connection".

BS 7671 90°C cable tables (Tables 4E) state that; “Where cables in this table are connected to equipment or accessories designed to operate at a temperature not exceeding 70°C, the current ratings given in the equivalent table for 70°C thermoplastic insulated cables (Table 4D4A) must be used (see also Regulation 523.1)”.

The above specifically applies to low voltage switchgear and controlgear assemblies which include Consumer Units, Distribution Boards, Panelboards, Switchboards and Motor Control Centres. It also applies to wiring accessories which includes wall switches, socket-outlets, fused spurs and plugs.

The British (BS) and harmonized (BS EN / BS EN IEC) standards for these products contain test limits that apply to thermoplastic insulation i.e. PVC, and specifically to low voltage assemblies, where the terminals of the built-in component e.g. MCCBs/MCBs, also contain the terminals for external insulated conductors.

Unless specified by the manufacturer, conductors operating at a temperature exceeding 70°C are not suitable or safe for use with wiring accessories, low voltage switchgear and controlgear assemblies. However, 90°C rated cable can be used for external wiring provided the conductor operating temperature does not exceed 70°C i.e. where the electrical design is based on current ratings given in the equivalent table for 70°C thermoplastic insulated cables.

Specifically for a low voltage switchgear and controlgear assemblies, whenever a declaration states that **built-in components (e.g. MCBs / MCCBs) which also contain the terminals for external insulated conductors**, are suitable for conductors operating at a temperature exceeding 70°C, then the **components must have been tested in the assembly as part of the appropriate assembly standard**.

5.4. Overcurrent coordination of devices from different manufacturers

Backup protection of a circuit-breaker by use of an SCPD is only accurately verified by test, appropriate data can be obtained from the manufacturer.

Selectivity between devices is only precisely established by test; however, guidance for a method of establishing selectivity by a desk study is given below.

5.4.1. Selectivity in the overload zone – Circuit-breakers in series (downstream (C1) and upstream (C2)) – selectivity determination by comparison of characteristics.

Selectivity in the overload zone is verified by comparison of the time/current characteristics, Separation of the characteristics in both the time and current axes ensures selective operation of C1 with respect to C2, in this zone. There will be a tolerance applicable to the characteristics, which should be taken into account. The manufacturer’s data should show a tolerance band or otherwise indicate the tolerance applicable, as required by the product standard.

5.4.2. Circuit-breaker (C1) with fuse as SCPD – selectivity determination by comparison of characteristics

Selectivity in the overload zone is determined by the comparison of time/current characteristics. Separation of the characteristics in both the time and current axes ensures selective operation of C1 with respect to C2, in this zone. There will be a tolerance applicable to the characteristics, which should be taken into account. The manufacturer’s data should show a tolerance band or otherwise indicate the tolerance applicable, as required by the product standard.

5.4.3. Determination of selectivity in the fault current (short-circuit) zone

Determination from time/current characteristics, of selectivity between two circuit-breakers in the fault current (short-circuit) zone, is limited to the case where C2 has a short-circuit release time-delay function provided by an electronic release.

5.4.4. Circuit-breakers in series (C1 and C2) – selectivity determination by consideration of peak let-through current

In the case where the instantaneous tripping of C2 depends on an electromagnetic effect (i.e. thermal/magnetic or magnetic-only circuit-breaker) or in the case of an electronic trip unit with an instantaneous release, the minimum level of selectivity between two circuit-breakers in the fault current zone may be determined as follows:

Selectivity is assured up to the fault current level at which the peak current let-through of C1 is less than the peak value corresponding to the instantaneous tripping level (I_i) of C2 taking into account the tolerance.

EXAMPLE:

C2 = 800 A MCCB; $I_i = 8 - 12$ kA RMS (10 kA setting ± 20 %); C1 = 125 A MCCB.

Minimum tripping level of C2 is $8 \times 1,414 = 11.3$ kA peak.

Let-through current of C1 at 15 kA RMS prospective, due to the current limitation of C1, is 11 kA peak, from test data.

Therefore the system is selective to at least 15 kA RMS prospective.

Note: the selectivity limit obtained by this method will err on the low side and the actual limit determined by test will be significantly higher in most cases.

Circuit-breaker (C1) with fuse as SCPD

Selectivity in the fault-current (short-circuit) zone (see 3.11) is determined from the I^2t characteristics. The selectivity limit current I_s is the maximum value at which let-through I^2t of the circuit-breaker is lower than the pre-arcing I^2t of the fuse. In the absence of an actual curve the manufacturer's quoted I^2t pre-arc value for the fuse is taken.

5.4.5. Determination of selectivity limit current for specific installation conditions

Data on selectivity limits may be supplied in tabulated form, graphically or as software media. Data obtained from either a desk study or tests, to this standard, will be based on the prospective fault current level at the incoming device (C2) and assumes that the coordinated devices are in close proximity. In practice the selectivity limit will be influenced by the impedance between the two devices. Therefore, in the practical situation taking the prospective fault current at the downstream circuit-breaker will give a more precise value for the selectivity limit.



Rotherwick House
3 Thomas More Street
London E1W 1YZ

www.beama.org.uk