



Issued 17th February 2011

Additional guidance for underfloor heating systems on how to comply with 2010 Building Regulations Part L

This document is intended to offer specific guidance when installing heating controls for warm water underfloor heating systems. It is intended to support section 7, 'Underfloor heating systems' in the Domestic Building Services Compliance Guide 2010 issued by the Department for Communities and Local Government which came into effect from October 1 2010.

The recommended system diagrams and additional notes based on the Guide will help to ensure that the essential requirements of the Building Regulations for this type of underfloor heating will be met.

Additionally guidance is offered for warm water underfloor heating used in commercial applications in line with the Non- Domestic Building Services Compliance Guide, although no specific underfloor heating section is included in the Guide.

Additional Notes

1. An underfloor heating system should be provided with a means of operating at a water temperature suitable for its application.

See: Domestic Building Services Compliance Guide 2010 Edition, Table 29, item 1.0

- *For systems with a high temperature heat source, such as a boiler, then a mixing valve should be fitted to ensure that the temperature of the water to the floor is reduced to the correct temperature for the type of floor and for the designed comfort conditions. The mixing valve may be of a two, three or four port type and will usually give thermostatic control i.e. provide a fixed water temperature set by the installer to suit the system. Alternative types which provide a water temperature which will vary according to the outside temperature may also be used but are not mandatory.*
- *For systems with a low temperature heat source, such as a heat pump, it may not be necessary to use a mixing valve but this should be verified as individual types of heat pump can vary.*
- *A 'high-limit' thermostat shown as 'HL' in the following diagrams should be installed as an additional safeguard. The thermostat should be positioned to sense the flow temperature produced by the mixing valve and be set to limit the flow temperature to prevent damage to the floor and discomfort to the user.*

2. Each room should be provided with its own sensor, thermostat or programmable thermostat. Where two adjacent rooms have a similar function, e.g. kitchen and utility rooms, it may be possible to use one temperature control for both rooms.

See: Domestic Building Services Compliance Guide 2010 Edition, Table 29, item 2.0

UHMA



3. In a single storey, open plan dwelling where the living area is greater than 70% of the total area, separate temperature controls are not required

See: Domestic Building Services Compliance Guide 2010 Edition, Table 29, item 3.0c

4. Automatic reduction of room temperature when a room is unoccupied, for example at night, is recommended where an underfloor heating system uses a floor with a thick screed (greater than 65mm thickness)

See: Domestic Building Services Compliance Guide 2010 Edition, Table 29, item 3.0d

5. The heating system controls should be connected so that when there is no demand for heat, the heat source and pump are switched off.

See: Domestic Building Services Compliance Guide 2010 Edition, Table 29, item 4.0

- *The 'wiring interlock centre' shown as 'WIC' in the following system diagrams should incorporate connections for the boiler and the underfloor heating pump which are de-energised when there is no demand for heat from the underfloor heating controls*

6. An automatic by-pass is shown which may be necessary where a boiler manufacturer's instructions require a by-pass to be fitted

See: Domestic Building Services Compliance Guide 2010 Edition, Table 1, item 2.0

7. Guidance for stored hot water controls should be taken from the TACMA document 'Guidance on how to comply with the 2010 Building Regulations Part L'

8. For additional information about Heat Pumps, see Section 9 of the Domestic Building Services Compliance Guide 2010 Edition

Additional requirements for installations

1. On completion of the installation all equipment should be commissioned in accordance with the manufacturers' instructions. The operation of all controls should be tested and the distribution system should be fully balanced to ensure correct operation of the underfloor heating system .

See: Domestic Building Services Compliance Guide 2010 Edition, Table 30, item 5.0

The Building Regulations 2000 Approved Document L1B 2010 Edition, Paragraphs 4.30 to 4.37

2. The installer must also give a full explanation of the system and its operation to the user. This will include a description of how to use all of the controls and the relevant User Instructions must be left with the user. For new systems in existing homes the Part L approved document states that "a way of complying would be to provide a suitable set of operating and maintenance instructions aimed at achieving economy in the use of fuel and power in terms that householders can understand in a durable format that can be kept and referred to over the service life of the system(s)."

UHMA

High Temperature Heat Source e.g.Boiler

Combi - Single Manifold UFH

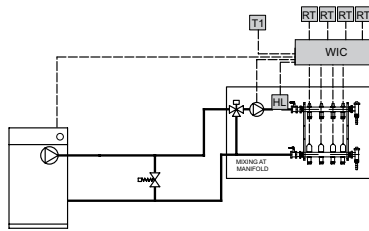

Traditional - Single Manifold UFH

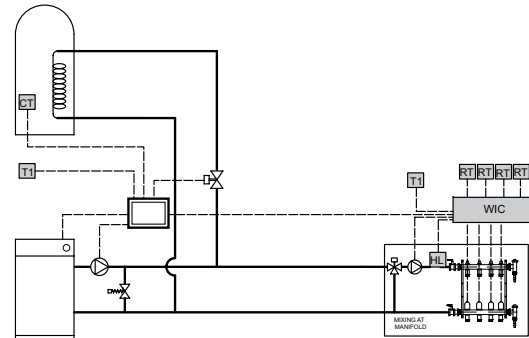

Traditional - UFH & Radiators

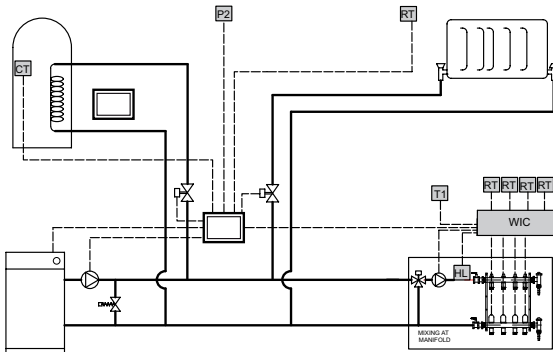

Traditional - Single Zone UFH & Radiators

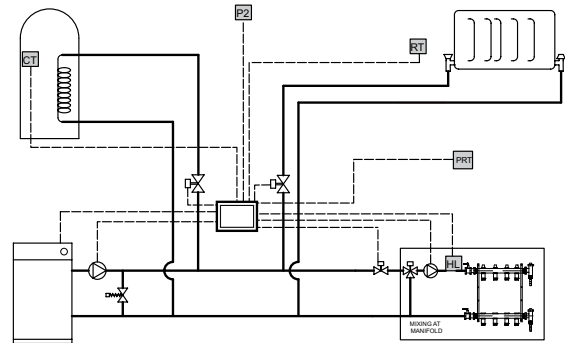

Low Temperature Heat Source e.g.Heat Pump

Heat Pump - Single Zone UFH

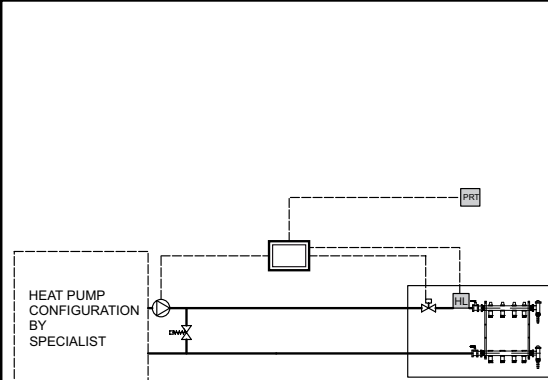

Heat Pump - Single Manifold UFH

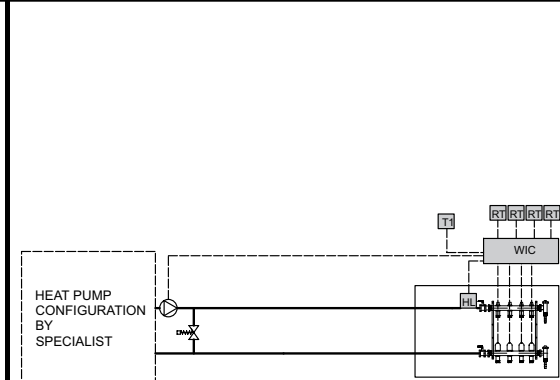

Dwellings up to 150m²

KEY TO SYMBOLS



UHMA

Dwellings over 150m²

High Temperature Heat Source e.g.Boiler

Traditional - Multiple Manifold UFH

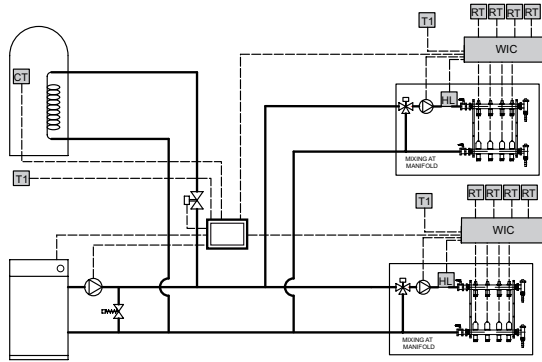

Traditional - UFH & Radiators

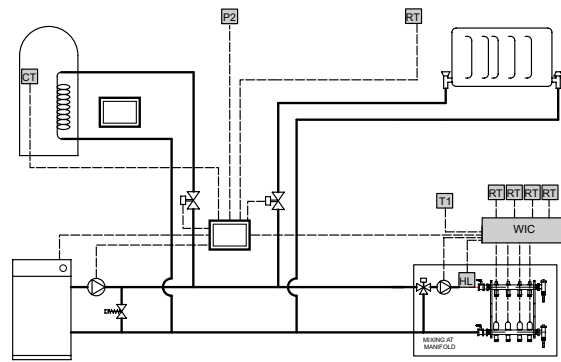

Low Temperature Heat Source e.g.Heat Pump

Heat Pump - Multiple Manifold UFH

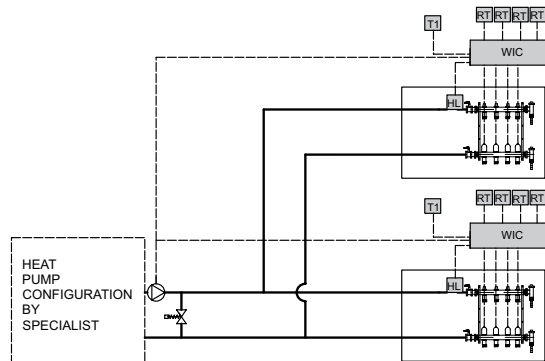

Heat Pump - Single Manifold UFH

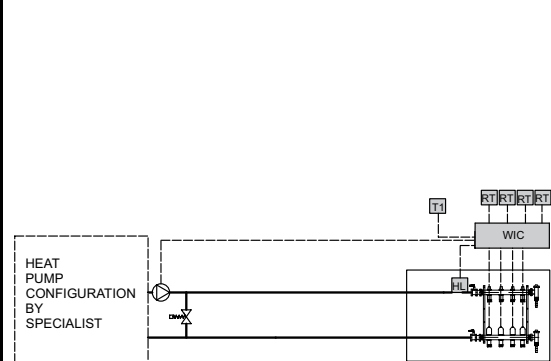

KEY TO SYMBOLS

